



Ruckus Wireless: Beyond LTE unlicensed, with LTE plus Wi-Fi link aggregation

A conversation with
Steve Hratko,
Director of
Service Provider Marketing,
Ruckus Wireless

By **Monica Paolini**
Senza Fili

In collaboration with

RCR Wireless
INTELLIGENCE ON ALL THINGS WIRELESS

**SENZA
FILI**

Sponsored by

 **RUCKUS**
Simply Better Wireless.

Ruckus Wireless: LTE unlicensed and Wi-Fi

There are two dimensions that are crucial to the deployment and success of LTE in the 5 GHz unlicensed band: spectrum and site acquisition.

Spectrum in the 5 GHz band is license-exempt virtually everywhere, but LTE unlicensed can realistically use that band only if it coexists with Wi-Fi fairly.

Site acquisition is equally crucial as LTE unlicensed is going to be tied to small-cell deployments, which will mostly occur in indoor locations. Operators will need easy and affordable access to these indoor venues to be able to successfully deploy LTE unlicensed.

Through its background in Wi-Fi, Ruckus Wireless is very familiar with both unlicensed spectrum and the needs of businesses and venues and intends to leverage this expertise to ensure that spectrum utilization in the 5 GHz band is fair to current and future tenants.

As a provider of high-performance Wi-Fi equipment for operator and enterprises, Ruckus understands the challenges that come from having large numbers of collocated Wi-Fi networks contending for access to spectrum.

A robust listen-before-talk mechanism is required to ensure coexistence. To retain a similarly fair environment in the 5 GHz band, Ruckus believes

that LTE unlicensed has to adopt listen before talk as well, even though this represents a departure from the way LTE normally operates.

The listen-before-talk approach is required to ensure fairness but is also crucial for operators to gain access to venues -- especially indoor venues.

Operators need to get consent and support of the entities that control these venues. That consent may be hard to come by if the venues' managers worry that LTE unlicensed may affect the performance of existing Wi-Fi networks, which are often mission critical to their operations.

Ruckus has experience in working with public venues and private enterprise in developing a wireless strategy that helps them meet their business needs.

Wi-Fi has a crucial role to play here as do LTE small cells. Increasing the performance of LTE small cells by using the unlicensed bands can make for an even better user experience in venues or businesses, provided it is done properly. In most cases this means supporting listen before talk to ensure fair access the spectrum.

This flexible approach makes it possible to support a variety of business models, which may be driven by capex commitments from the service providers, enterprises, or neutral-host parties.

While much of the debate today revolves around the role of LBT in deployments of LTE unlicensed, LTE Wi-Fi Link Aggregation, or LWA, has emerged as a new option. With this approach LTE traffic is simultaneously sent over both LTE and Wi-Fi

radios. A separate SSID is configured on the Wi-Fi access point for this purpose.

LWA gives Ruckus an opportunity to expand its solution portfolio by allowing traffic that currently uses LTE to transit its commercially deployed Wi-Fi networks.

LWA's objective is similar to that of LTE unlicensed, but its focus is on leveraging the advantages of Wi-Fi in the 5 GHz band and of LTE in the licensed spectrum.

Ruckus believes this approach leads to a more efficient use of the 5 GHz band, because Wi-Fi is designed for this environment, and LTE is optimized for licensed bands. Each will be allowed to do what they do best.

Convergence of Wi-Fi and LTE



Source: Ruckus Wireless

Beyond LTE unlicensed, with LTE plus Wi-Fi link aggregation

A conversation with
Steve Hratko,
Director of
Service Provider Marketing,
Ruckus Wireless

Monica Paolini: Good afternoon, and welcome to our conversation on LTE unlicensed and its coexistence with Wi-Fi. Today, we are talking to Steve Hratko, the director of service provider marketing at Ruckus Wireless.

Steve, thanks for talking to us today.

Steve Hratko: It's always a pleasure, Monica.

Monica: Steve, how do you rationalize your involvement with both Wi-Fi and LTE unlicensed?

Steve: Ruckus Wireless has been in the Wi-Fi business for more than a decade, and we specialize in two primary markets.

We have a pretty significant enterprise business that focuses on venues like airports, train stations, hotels, et cetera. We also have a large service provider business, and the service provider

business focuses on the needs of both mobile operators and cable operators, along with wireless ISPs and managed service providers.

As part of our focus on service providers, we've been taking a long, hard look at LTE in the unlicensed band. At Ruckus, we use these bands for Wi-Fi, which has been an enormously successful business, largely because of its ability to share unlicensed spectrum. The unlicensed bands are free for anyone to use, for any purpose.

Now, with the arrival of LTE-U, we've been taking a look at what impact this will have on the unlicensed bands. We certainly understand the driver for LTE-U, which is how best to use this spectrum to provide a more compelling, higher-performance LTE service. At Ruckus, we want to understand how LTE-U is going to impact Wi-Fi services, which are broadly deployed and very successful.

Monica: As you said, Wi-Fi has been very successful. It has also taught us a lot about how different networks can coexist in the same frequency band. Can we expand to other technologies, like LTE unlicensed, what we learned with Wi-Fi? What is necessary for the two technologies to coexist?

Steve: There's an established mechanism for Wi-Fi networks to share spectrum, called listen before talk. With listen before talk, the Wi-Fi device waits for the channel to be clear, and when it is, it transmits. Typically, an AP would transmit for up to 10 milliseconds, then it would release the channel and the process repeats. This works extremely well for the sharing of the unlicensed bands.

This isn't terribly efficient – and certainly not as efficient as LTE, which uses a scheduled MAC process – but it works extremely well for sharing unlicensed spectrum.

The big debate within 3GPP right now about LTE-U is just exactly how LTE might implement listen before talk, or will it implement something different? A lot of the early work around LTE-U is not focused on using listen before talk per the IEEE, but is instead focused on looking at other approaches that might be a better fit for LTE.

We're advocating, along with the whole Wi-Fi industry, that 3GPP come forward in Release 13 with an approach that supports listen before talk. This is going to make LTE-U and, more specifically, LAA-LTE much more successful.

Monica: Do you think there is enough consensus in the industry – not just from the Wi-Fi side, but from all the LTE players – to support listen before talk?

Steve: I think the consensus in the industry is to move towards implementing listen before talk for LTE-U. We think this will be done by 3GPP in Release 13 as LAA-LTE.

There are a number of reasons for this.

The first reason is that in some jurisdictions, specifically in the European Union, it's required by regulation. It's not required by regulation in the US and some other markets, but in the interest of having a solution that works worldwide, it makes sense to implement listen before talk. I think it's going to make everything run a lot smoother.

The second reason is that there is a huge installed base of Wi-Fi equipment, and it is in everyone's best interest for LTE-U to work with that installed base and to share spectrum fairly.

A third factor, which doesn't get enough attention in the listen-before-talk debate, is that LTE-U and LAA-LTE are small-cell technologies. LTE-U and LAA-LTE operate on the unlicensed band, so you have the same power limitations that Wi-Fi has and they are ideally suited to high-capacity-density venues.

Those are locations where Ruckus has a lot of expertise. Stadiums, train stations, convention centers, airports, downtown city centers, areas where you have huge numbers of people aggregating in close proximity, and they are all using data. One of the challenges with addressing this opportunity is that in almost all cases, to deploy any radio technology will require the permission of the venue.

If it's a downtown city center, you've got to go through a large number of municipal commissions and committees. It's going to be easier to get permission to deploy LTE small cells if they don't impact the Wi-Fi networks already deployed.

An operator proposing to install LAA-LTE-enabled small cells with listen before talk will have a much easier time passing muster with that stadium, with that convention center, with that airport.

In many cases, these venues have people whose job it is to keep an eye on how the unlicensed bands are being used, because Wi-Fi services are so important to the venue -- in many cases are

mission critical. Any solution that's not IEEE compatible is going to get a lot of scrutiny.

Monica: Is the enterprise going to allow somebody else to come and use the same spectrum?

Steve: At these very high-capacity-density venues, it's very important to make sure that you meet the needs of the venue. This applies whether you're deploying Wi-Fi in that venue, or LTE small cells, or LTE small cells using LTE-U. In all cases you have to understand the needs of the venue.

Many of us pick venues based on how good the Wi-Fi is. People who enter these venues expect high-quality Wi-Fi, so anything that potentially impacts the Wi-Fi networks is going to get looked at very closely by the venue.

Now, it's possible that even if you implement LAA-LTE with listen before talk, the venue still may not like that. They still may prefer that the LTE stay in the licensed band, and the Wi-Fi stay in the unlicensed bands.

It's going to be their choice, because they control access to the facility. Again, they are an important constituent in this debate, and I think we need to hear more from them going forward.

This convergence of service providers and public venues is the sweet spot for Ruckus, in that we build very high-end Wi-Fi gear that's designed for these sorts of installations, and so we have a good sense of what venues are looking for, what's important to them, what the industry needs to do.

Monica: Now, from a mobile operator point of view, there is the opportunity not only to use LTE unlicensed, but also LTE unlicensed and Wi-Fi in a much more tightly integrated way.

Steve: There is a focus in the industry on combining LTE small cells with Wi-Fi access points -- putting both radios into the same box. We're already working with major RAN vendors that are looking to add Wi-Fi to their small-cell products.

Part of the challenge is that site acquisition is difficult when deploying any kind of a small radio in a high-density venue. Once you get permission to deploy, you might as well deploy a box that does more things. If you have Wi-Fi in the box, add an LTE small cell. It makes a lot of sense to combine them, and we expect to see a lot of that going forward.

But it introduces some interesting problems that have not gotten enough attention in the industry.

If you have a single node with both a Wi-Fi access point and an LTE-U small cell, you end up in a situation where that node has two 5 GHz radios operating at the same time. Running the Wi-Fi and LTE-U radios together in the same box with antennas in very close proximity requires very sophisticated filtering.

People haven't been spending enough time figuring out how that's going to work. And these challenges bring us to LWA. I have a feeling we're heading in this direction.

Monica: What's happening with LWA?

Steve: LWA is LTE plus Wi-Fi link aggregation. It is another proposal coming from our friends at Qualcomm. It builds on the original LTE-U concept.

As with all things, with each iteration the technology gets better and the solutions get better. At Ruckus, we're big fans of LWA. In the end, it will prove to be a stronger solution than running LTE directly over the unlicensed band.

The theory here is that rather than try to put a 5 GHz unlicensed radio inside an LTE small cell, you'll have Wi-Fi access points running in the unlicensed band, and you'll have LTE small cells running in the licensed band. You let each of them do what they do best.

The smartphone would turn on both of its radios and send some of the data natively over LTE, and the rest as a tunnel over Wi-Fi.

You're running LTE in the unlicensed band, but you're using the Wi-Fi MAC and PHY. You don't have any of the issues with listen before talk and fair sharing that come with LTE-U. When the LWA signal arrives at the Wi-Fi access point, it is peeled off and tunneled back to the eNB, where the Wi-Fi and LTE signals are combined and sent back to the mobile core.

This is a really nice solution, because it gets us out of that debate over running LTE in an unlicensed band, something it was never designed to do.

By recombining the Wi-Fi data at the eNB, you can bring it all back into the mobile core without having to go through any 3GPP S2A, S2B, or S2C interfaces, which are normally used to bring Wi-Fi

Link aggregation with LTE and Wi-Fi (LWA)

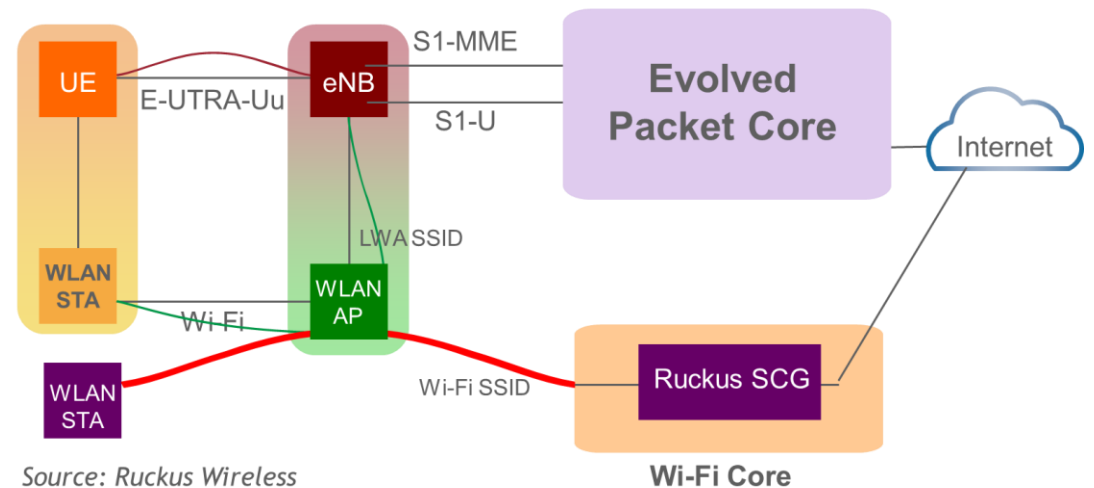

data into the mobile core. It's just going to be a straight S1 interface through a Serving Gateway

There's a lot of value in this approach. It is the right way to give cellular service a boost, by letting it tap into that enormous pool of bandwidth we have in the unlicensed bands. In the US, there is close to 700 MHz. This varies by geography, but there is a significant amount of unlicensed bandwidth, and it can be shared.

Monica: LWA is also something that 3GPP is working on – it's not a proprietary solution.

Steve: The industry has been trying to understand how to do Wi-Fi and cellular convergence now for close to a decade. There have been a number of different approaches that have been queued up, and I think everybody agrees that Wi-Fi and cellular technologies can be combined to offer a truly compelling user experience.

We have to figure out how to make them converge so that the user is always best connected. Sometimes cellular is the better connection. Sometimes Wi-Fi is the better connection. But regardless of which one's better, how do we combine them?

Monica: From the operational and business model point of view, how will the LTE-U and LWA models work? That's an even a bigger challenge than working out the technology issues, How will this get deployed in venues and who will pay?

Steve: I think that's a fascinating question, and I think we are well-positioned to answer it.

Many of the technical issues around deploying LTE small cells have been worked out by the RAN industry. Now we're going down the path of trying to understand how to use LTE in the unlicensed band.

As we start looking to deploy small cells, whether it's just a straight LTE small cell or an LTE small cell using the unlicensed band, what does the business model look like?

In a convention center or an airport, mobile operators are going to want to deploy LTE small-cell networks. Each operator will negotiate with the venue, put in its own network, and pay the venue whatever site rental fee is required.

But once you get past the high-capacity-density venues, you're looking at smaller venues, like the tens of thousands of hotel chains in the United States and around the world. You're also looking at hospitals, shopping malls and universities.

We've learned a couple of lessons from deploying Wi-Fi in public venues of various types.

Number one, once you're past the high-capacity-density venues, the enterprise or venue has to pay. For almost any radio deployment, whether it's Wi-Fi or LTE, you've got to come up with a model where the venue will pay to deploy the equipment.

Number two, it should be deployable by a value-added reseller, or VAR. If radio engineers are required, things can get really expensive. Obviously, you need to make the deployment as easy as possible, and have that equipment be as cost effective as possible.

We've seen a lot of projections from analysts talking about the LTE small-cell market being worth upwards of \$10 billion in five years. But to

get there, we've got some business model challenges we need to address.

Monica: As you move to smaller venues, you still want multiple operators, but it becomes increasingly difficult to have multiple operators deployed side by side. So you need a DAS-like neutral-host model. Do you think it will work for indoor LTE-U or LTE licensed small cells?

Steve: To get the venue to pay for the deployment, it has to be a neutral-host model. Everyone who walks into that venue has to be able to access that network. Venues don't want to put in three or four networks, they want just one. That's why Wi-Fi has been so successful. A single Wi-Fi network is a perfect neutral-host solution, because everybody who walks into the venue can connect.

We need to do the same with LTE. We need to find a way to make the neutral-host model work with LTE. The venue will pay to deploy the network, and anyone who walks into the building will be able to use that small-cell network. Venues won't pay for two, three or even four networks, but they will pay for one.

To make the small-cell LTE market really explode, we've got to solve the neutral-host problem.

Monica: Is there a difference in terms of geography? In the US, there is much less of an infrastructure-sharing mentality than in places like Europe, for instance.

Steve: Yeah, RAN sharing tends to be much more popular overseas.

A widening role for neutral host models for LTE small cells

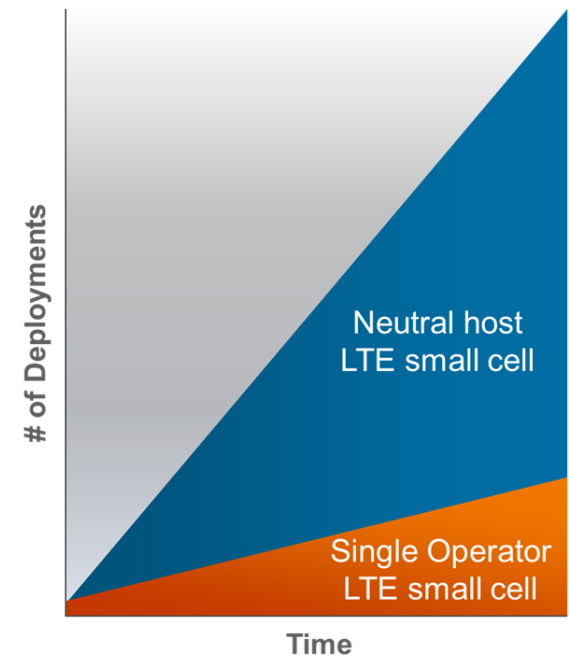

Source: Ruckus Wireless

The neutral-host model is now becoming a top-of-mind issue for the LTE small-cell industry, especially, as we start looking at potentially running LTE in the unlicensed band. The industry needs to better understand the business model and better understand how to neutral-host the technology.

Monica: What do you see in the short- to mid-term for the coexistence of Wi-Fi and LTE unlicensed?

Steve: I think the key right now is what's going to happen at 3GPP. They've taken on the challenge of

looking at LTE-U and trying to understand how to standardize it.

I think everybody wants to see a standard come out of 3GPP, and that's targeted for Release 13 in the summer of 2016. We believe that at that time, 3GPP will come up with a mechanism that supports listen before talk per the IEEE. There are so many reasons to go down that path that we expect that to happen.

Separately, we also have LWA, and that's being worked by 3GPP, also, for Release 13. We should see something big coming out in the summer of 2016. There's going to be a great deal of interest in terms of understanding what 3GPP is doing there.

Certainly, a lot of the Wi-Fi standards organizations are also plugging themselves in to the 3GPP process. I think we'll come out with a solution that's going to be a win-win for the entire industry.

Monica: Is this going to make the small-cell market bigger, or is it just going to have a larger benefit for Wi-Fi?

Steve: These approaches accelerate the convergence, which is good for everyone. We've

been working to converge Wi-Fi and cellular for some time now, and approaches like LTE-U and especially LWA accelerate that convergence, as do things like Hotspot 2.0 and Wi-Fi Calling.

Anything that helps to accelerate this convergence makes a more compelling user experience for people using wireless services, and I think it's going to be a plus for the entire industry.

Glossary

3GPP	Third Generation Partnership Project
AP	Access point
DAS	Distributed antenna system
eNB	Evolved NodeB
E-UTRA	Evolved Universal Terrestrial Radio Access
IEEE	Institute of Electrical and Electronics Engineers
LAA-LTE	Licensed-assisted access LTE
LTE	Long Term Evolution
LTE-U	LTE unlicensed
LWA	LTE Wi-Fi Aggregation
MAC	Media Access Control [layer]
MNO	Mobile network operator
MSO	Multiple-system operator
PHY	Physical (layer)
RAN	Radio access network
SCG	Small-cell gateway
SSID	Service Set Identifier
STA	Station
UE	User equipment
VAR	Value-added reseller
WISP	Wireless internet service provider
WLAN	Wireless local area network

About Ruckus Wireless



Headquartered in Sunnyvale, CA, Ruckus Wireless, Inc. (NYSE: RKUS) is a global supplier of advanced wireless systems for the rapidly expanding mobile Internet infrastructure market. The company offers a wide range of indoor and outdoor “Smart Wi-Fi” products to mobile carriers, broadband service providers, and corporate enterprises, and has over 40,000 end-customers worldwide. Ruckus technology addresses Wi-Fi capacity and coverage challenges caused by the ever-increasing amount of traffic on wireless networks due to accelerated adoption of mobile devices such as smartphones and tablets. Ruckus invented and has patented state-of-the-art wireless voice, video, and data technology innovations, such as adaptive antenna arrays that extend signal range, increase client data rates, and avoid interference, providing consistent and reliable distribution of delay-sensitive multimedia content and services over standard 802.11 Wi-Fi. For more information, visit <http://www.ruckuswireless.com>.

About Steve Hratko



Steve Hratko is the Director of Service Provider Marketing at Ruckus Wireless. Steve is responsible for the marketing of all service provider class products worldwide. The primary markets for Ruckus solutions include MNOs, MSOs, WISPs, managed services providers and wireline providers. Steve’s specific areas of expertise include Wi-Fi technology, licensed radio technology (specifically small cells), mobile packet core and related systems. Steve has worked with service providers of all types and in all geographies. He has also been quoted extensively in industry press, written extensively on the wireless market, and spoken at a wide variety of wireless industry events. Prior to joining Ruckus in the spring of 2012, Steve served in a variety of product marketing positions at Juniper Networks and Cisco.

**This conversation is included in the Senza Fili report
“LTE unlicensed and Wi-Fi: Moving beyond coexistence,”
prepared in collaboration with RCR Wireless News and available for download
from www.rcrwireless.com and www.senzafiliconsulting.com**

About RCR Wireless



Since 1982, RCR Wireless News has been providing wireless and mobile industry news, insights, and analysis to industry and enterprise professionals, decision makers, policy makers, analysts and investors. Our mission is to connect, globally and locally, mobile technology professionals and companies online, in person, in print and now on video. Our dedication to editorial excellence, coupled with one of the industry's most comprehensive industry databases and digital networks, leads readers and advertisers to consistently choose RCR Wireless News over other industry publications.

About Senza Fili



Senza Fili provides advisory support on wireless data technologies and services. At Senza Fili we have in-depth expertise in financial modeling, market forecasts and research, white paper preparation, business plan support, RFP preparation and management, due diligence, and training. Our client base is international and spans the entire value chain: clients include wireline, fixed wireless and mobile operators, enterprises and other vertical players, vendors, system integrators, investors, regulators, and industry associations.

We provide a bridge between technologies and services, helping our clients assess established and emerging technologies, leverage these technologies to support new or existing services, and build solid, profitable business models. Independent advice, a strong quantitative orientation, and an international perspective are the hallmarks of our work. For additional information, visit www.senzafiliconsulting.com or contact us at info@senzafiliconsulting.com or +1 425 657 4991.

About the interviewer



Monica Paolini, PhD, is the founder and president of Senza Fili. She is an expert in wireless technologies and has helped clients worldwide to understand technology and customer requirements, evaluate business plan opportunities, market their services and products, and estimate the market size and revenue opportunity of new and established wireless technologies. She has frequently been invited to give presentations at conferences and has written several reports and articles on wireless broadband technologies. She has a PhD in cognitive science from the University of California, San Diego (US), an MBA from the University of Oxford (UK), and a BA/MA in philosophy from the University of Bologna (Italy). She can be contacted at monica.paolini@senzafiliconsulting.com